



20x20 Wallframe rental kit to include:

- (1) 4 x 8 x 16' tall hardwall closet with locking door
- (1) INWALL monitor mount
- (2) Double Sided 36" Box" workstation with black laminate top and built in monitor mount
- (1) "EV2" locking standalone counter, 46"w x 20"d black laminate top
- (1) silhouette lit graphic mount for front counter

CHOICE of black, white, or gray sintra provided standard for all solid infill walls that do not have graphics, unless described otherwise

\*White laminate standard for EV2 wall counter sides and standalone counter front and sides

Consult your account rep for options. Additional elements, merchandising and graphics are available

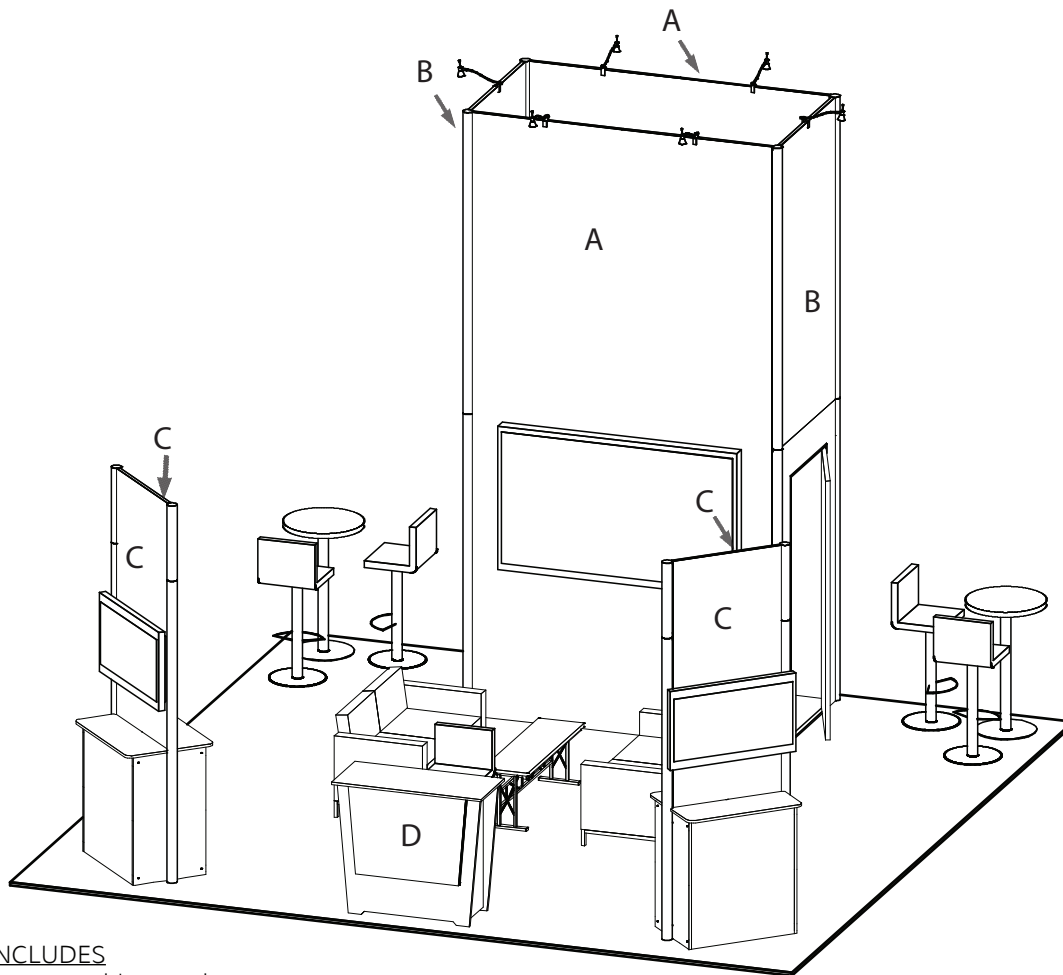

**GRAPHICS PACKAGE INCLUDES**

- A. - (2) 92" w x 184" h sintra graphic murals
- B. - (2) 46" w x 184" h sintra graphic murals
- C. - (4) 34.5" w x 75h" sintra graphic panels
- D. - (1) 36"w x 26.5" h profile cut sintra counter graphic

**KIT PACKAGE PRICING DOES NOT INCLUDE chairs, benches, tables, computers, monitors/cables, and carpet. Additional elements, merchandising and graphics are available through your account representative.**

**Please follow our graphic file submission guidelines for all printed elements to avoid resubmission requests and delay. Allow at least 10 business days for graphic production.**

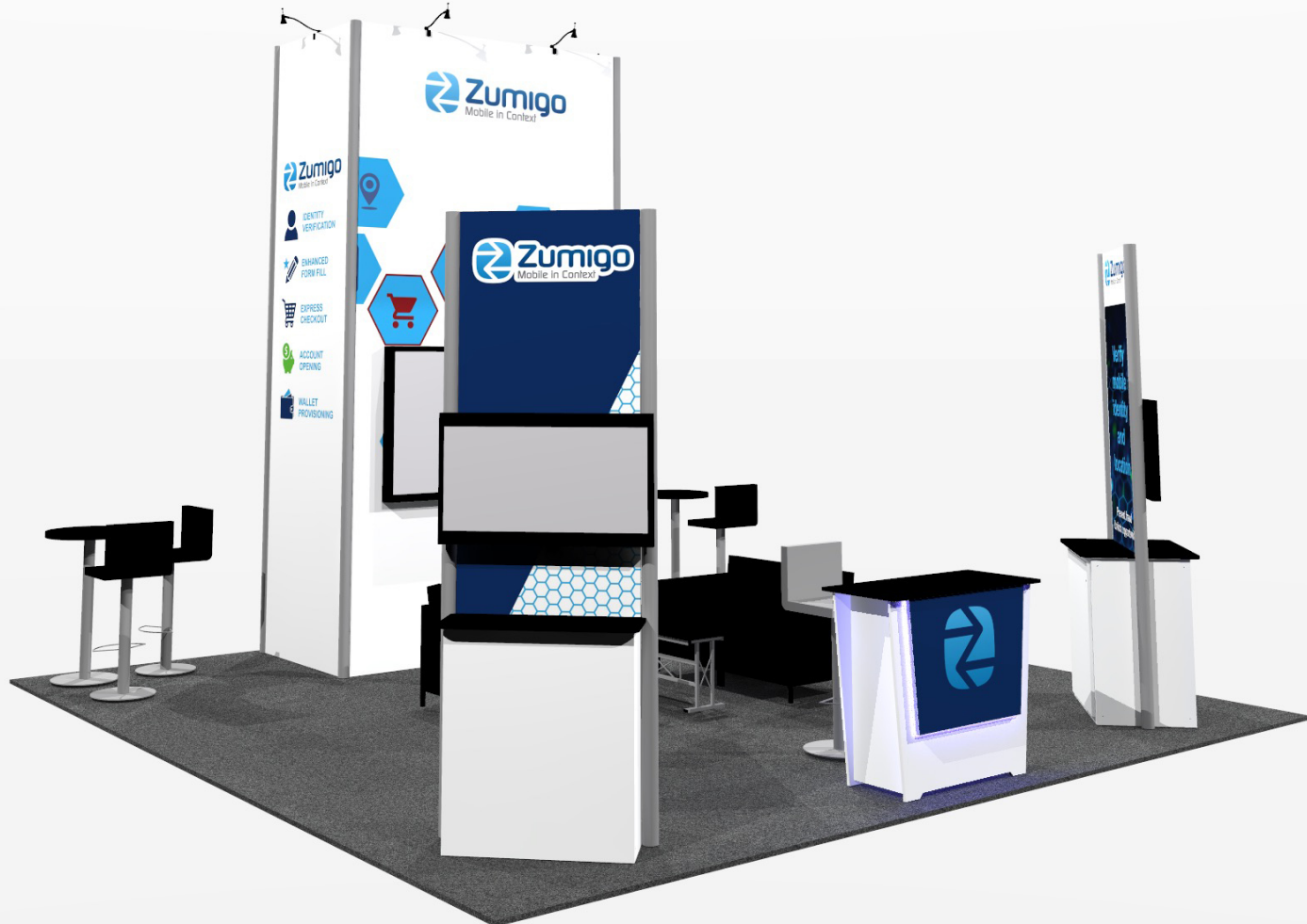

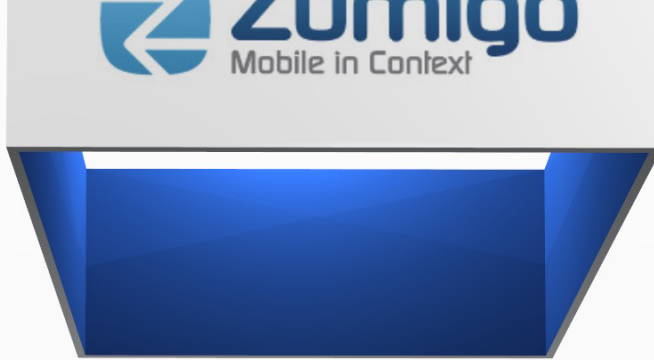





Automated mobile number detection on any smartphone



Stop fraud and seamlessly verify authentic users with zero knowledge proof identity risk assessment scores.



ENHANCED **MOBILE** IDENTITY

Zumigo uses intelligent networks to instantly verify.

The main vertical booth wall is white with a large blue section in the middle. The blue section has a background of white dots and lines, resembling a network or data flow. It contains the Zumigo logo and tagline at the top, followed by the headline 'Stop fraud and seamlessly verify authentic users with zero knowledge proof identity risk assessment scores.' Below the headline are two interlocking hexagons, one labeled 'ZERO KNOWLEDGE' and the other 'RISK SCORES'. At the bottom of the wall, the text 'ENHANCED MOBILE IDENTITY' is written in a large, bold font, with 'MOBILE' in blue. Below that, in a smaller font, it says 'Zumigo uses intelligent networks to instantly verify.'

Verify mobile identity and location

Prevent fraud  
Unlock opportunity

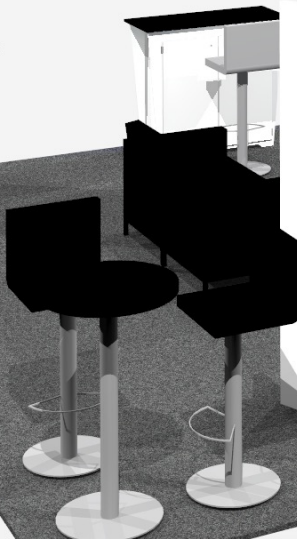
A small vertical booth wall with a white top section featuring the Zumigo logo and tagline. Below that is a blue section with the text 'Verify mobile identity and location' in white. At the bottom, in a smaller font, it says 'Prevent fraud' and 'Unlock opportunity'.

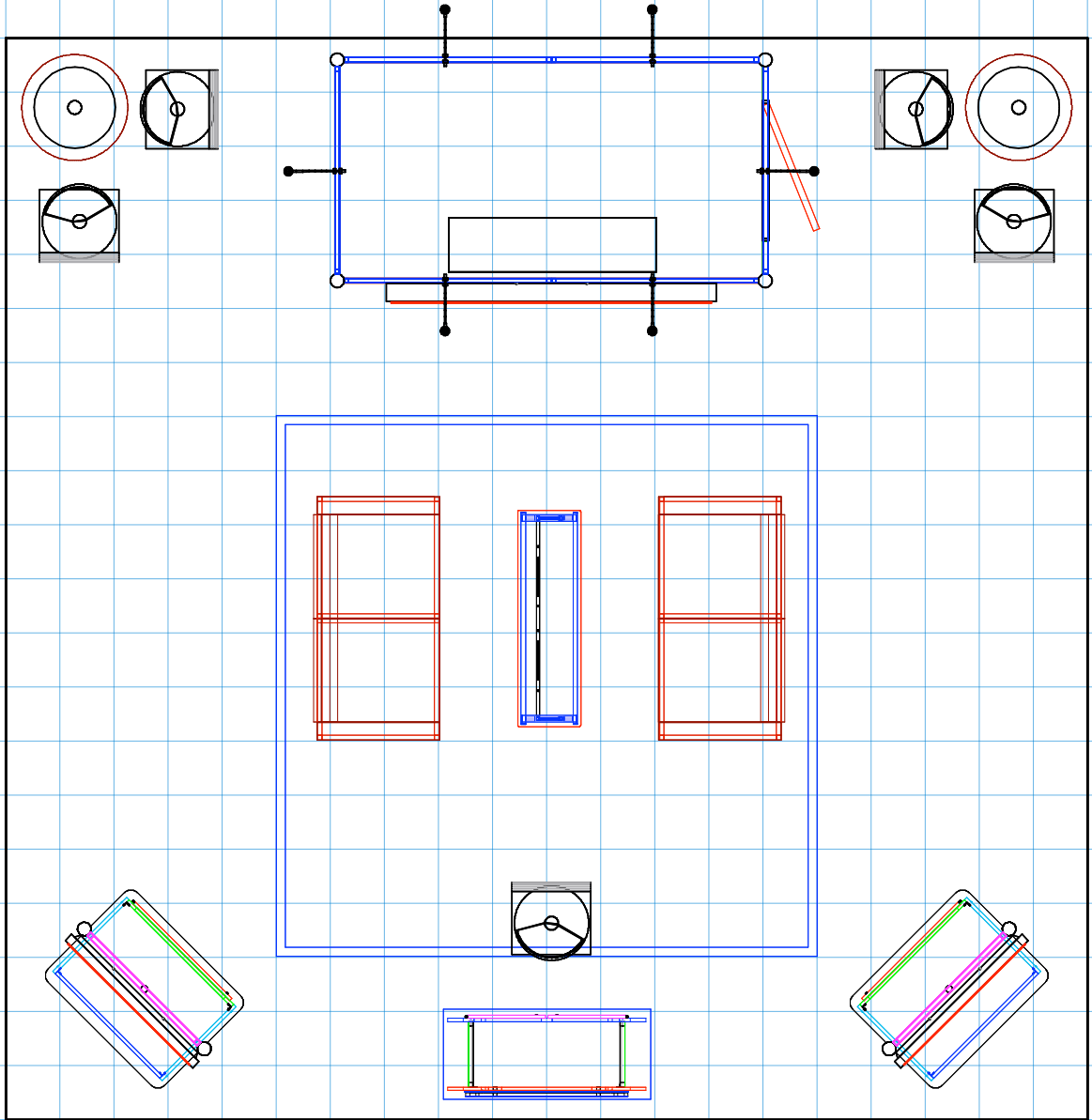

DRAWN BY: LH

**DESIGN : EV2-LL83**

**DATE: 12/16/22**

**REFERENCE: 20X20**

**© 2022**

The designs shown herein are protected by copyright and other laws. This document is to be maintained in confidence. No portion of the information or design shown herein may be reproduced, electronically or otherwise, nor may any display be made from this design without written consent.

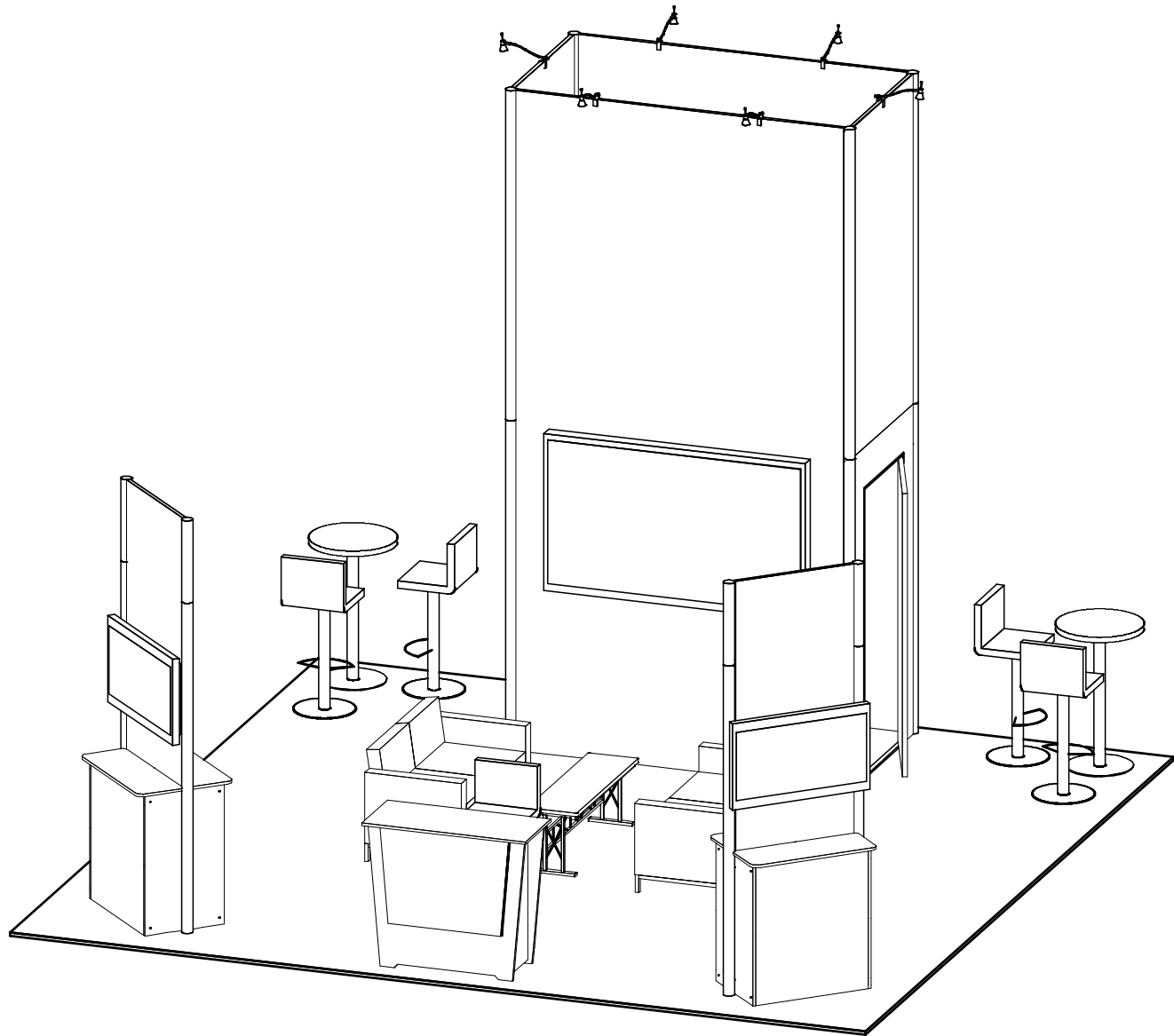

DRAWN BY: LH

**DESIGN : EV2-LL83**

**DATE: 12/16/22**

**REFERENCE: 20X20**

**© 2022**

The designs shown herein are protected by copyright and other laws. This document is to be maintained in confidence. No portion of the information or design shown herein may be reproduced, electronically or otherwise, nor may any display be made from this design without written consent.

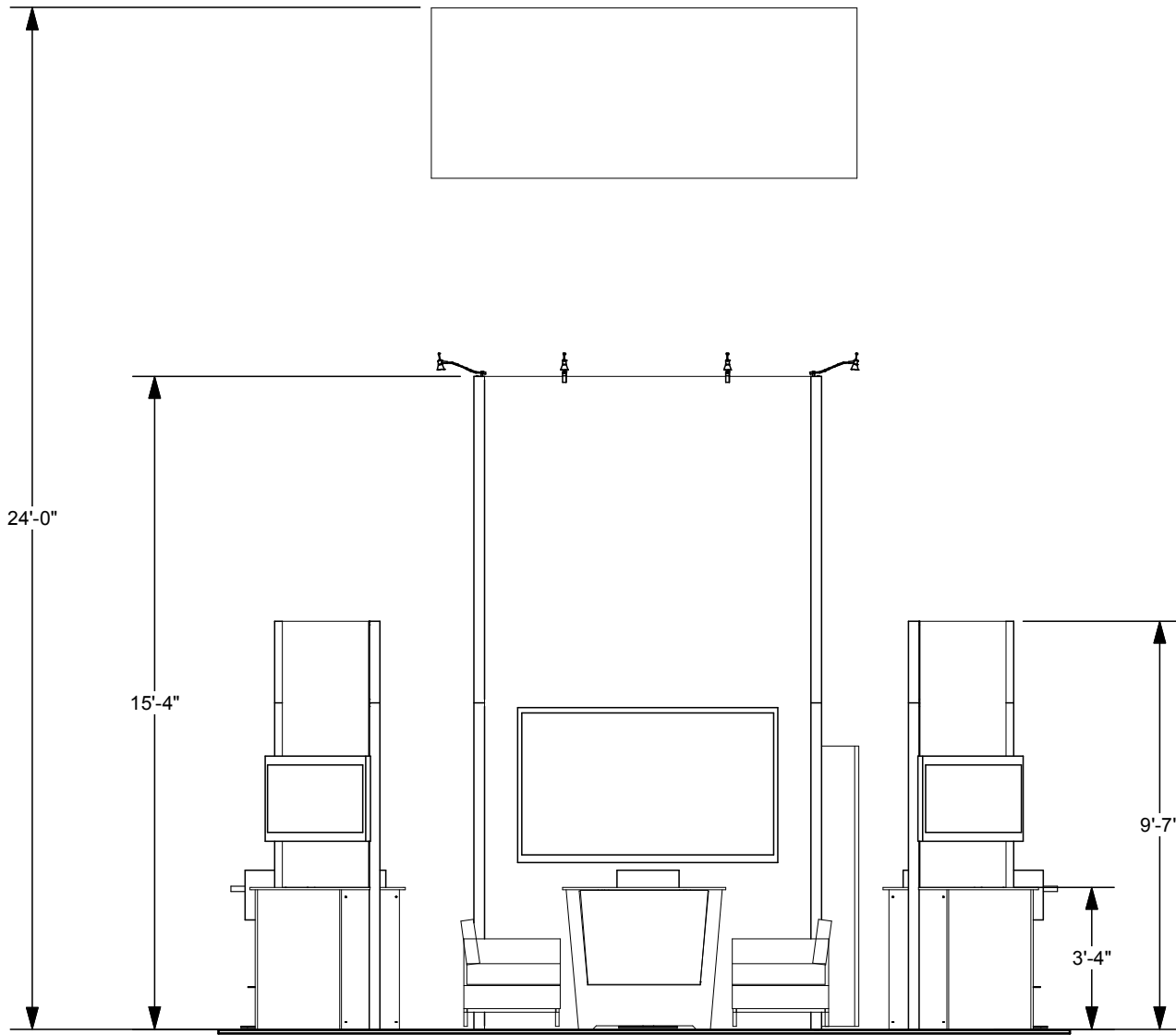

DRAWN BY: LH

**DESIGN : EV2-LL83**

**DATE: 12/16/22**

**REFERENCE: 20X20**

**© 2022**

The designs shown herein are protected by copyright and other laws. This document is to be maintained in confidence. No portion of the information or design shown herein may be reproduced, electronically or otherwise, nor may any display be made from this design without written consent.